

0

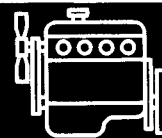

1



2



3



4



5

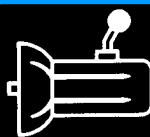

6

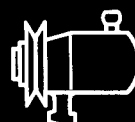

7



8



9



10



11



12



13



14

15





4

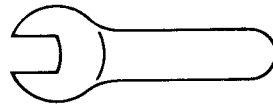

MA
312/1

1

OUT 20 6017 T

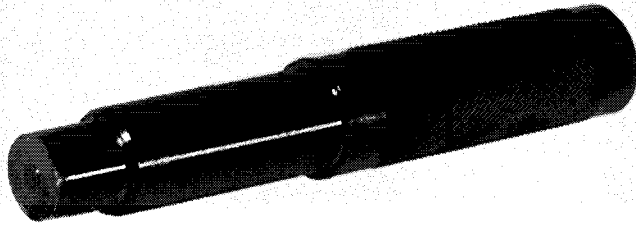

79.260

OUT 30 4062 T

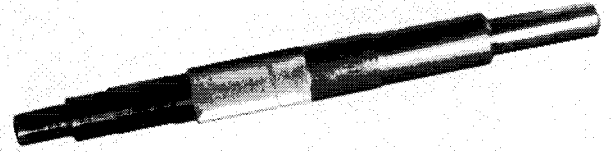

81.813



4

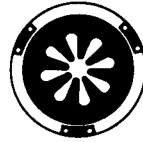

MA
312.00/1

1

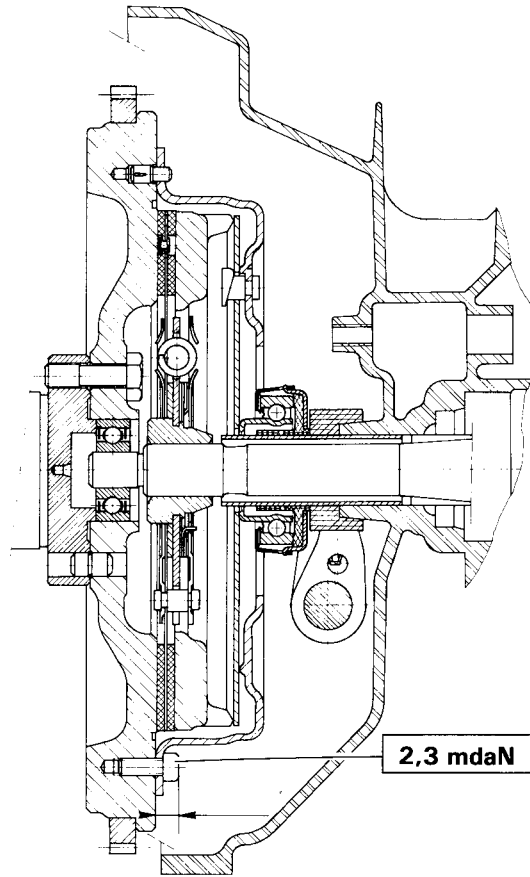

2,3 mdaN

→ 10/85	829.A5	215 mm	8	21	215 CP 450
	J6T A 500				215 CP 510
10/85 →	829.A5				235 DBR 450
	J6T A 500				235 DBR 525
	M25/660	228,6 mm			235 DBR 575
	M25/648				
	M25/659				
	M25/662				

2

MA
312.00/1

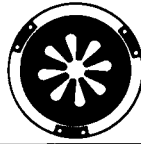

4



TT → 6/85

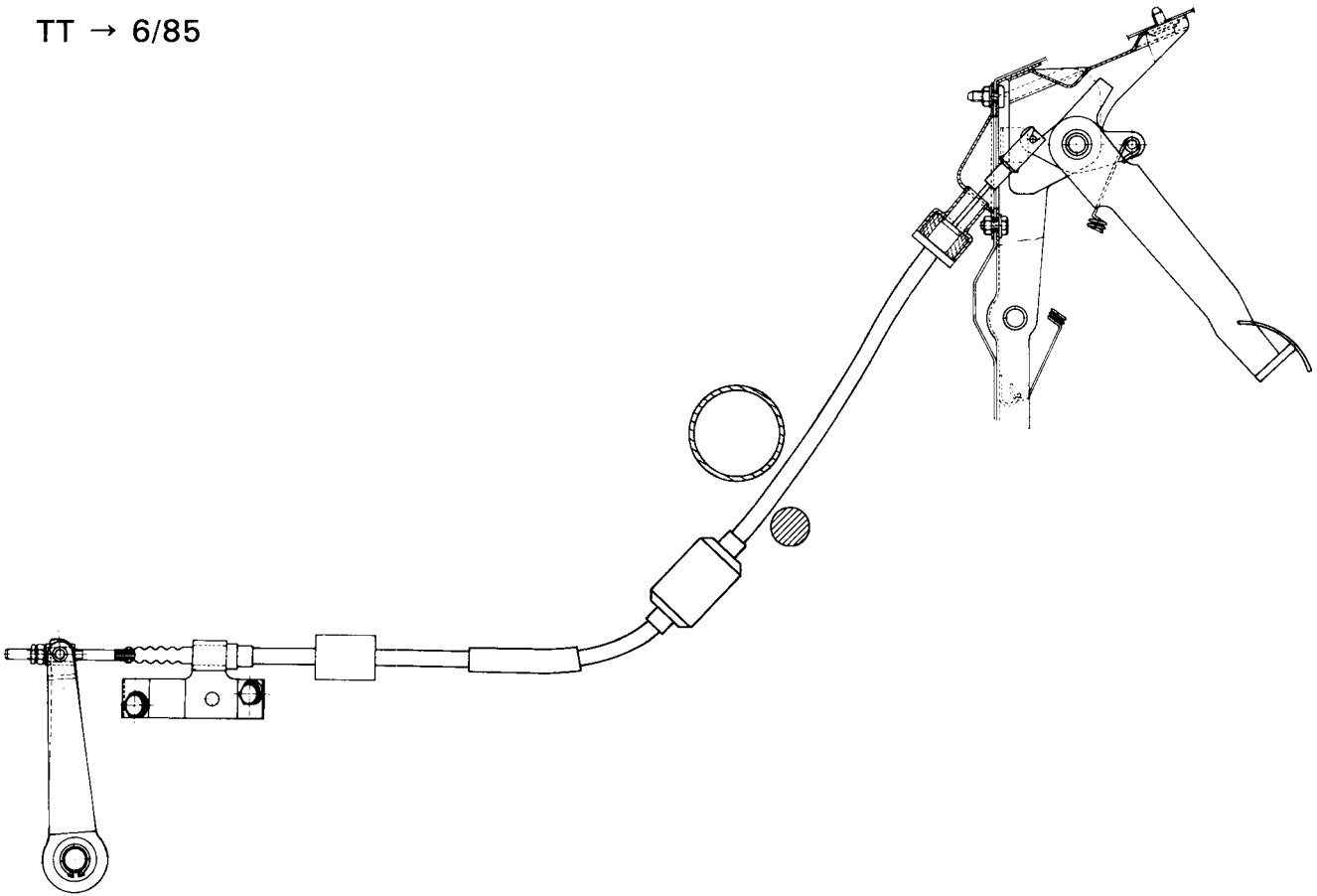

TT 6/85 →

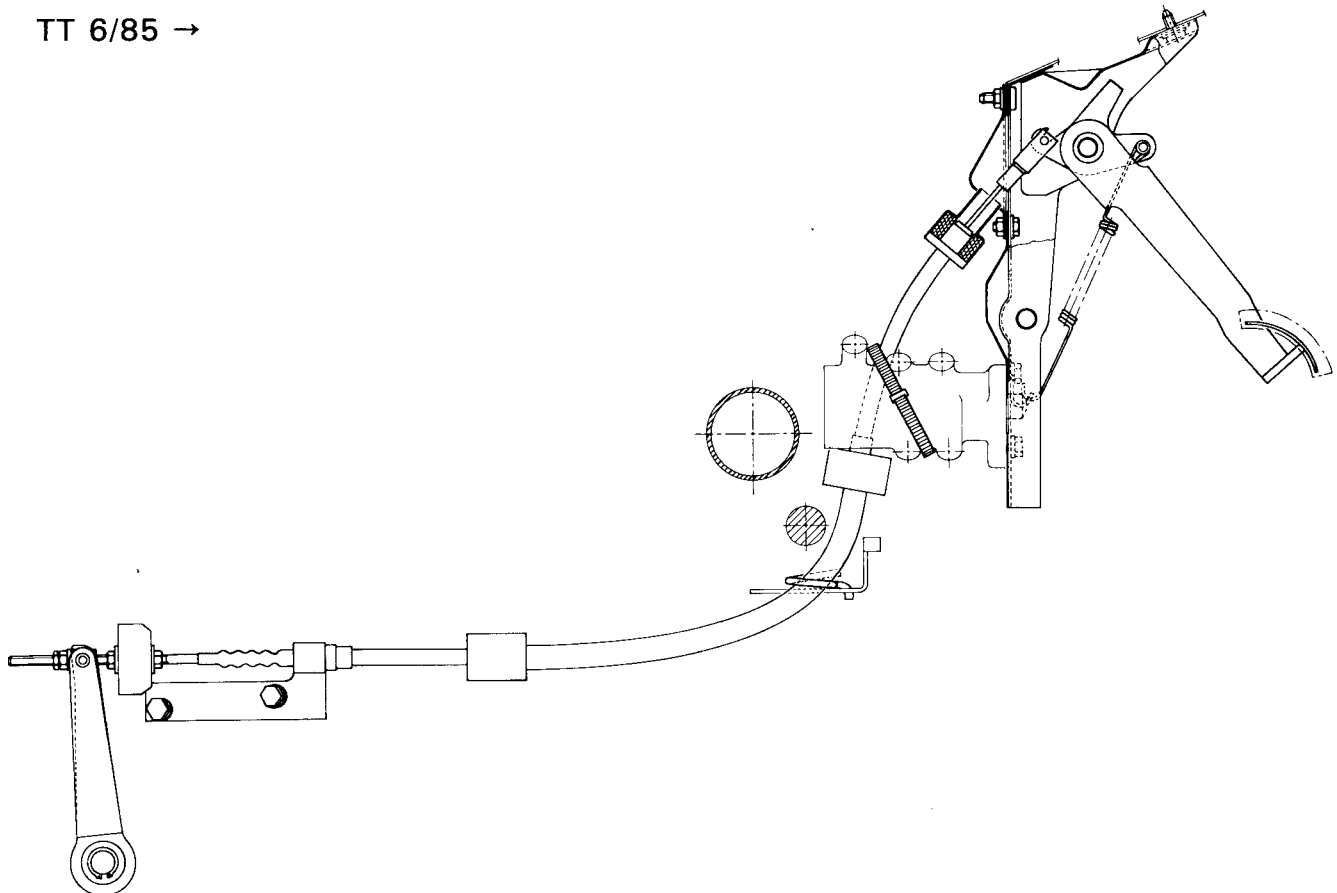



4



MA
312.0/1

1

